

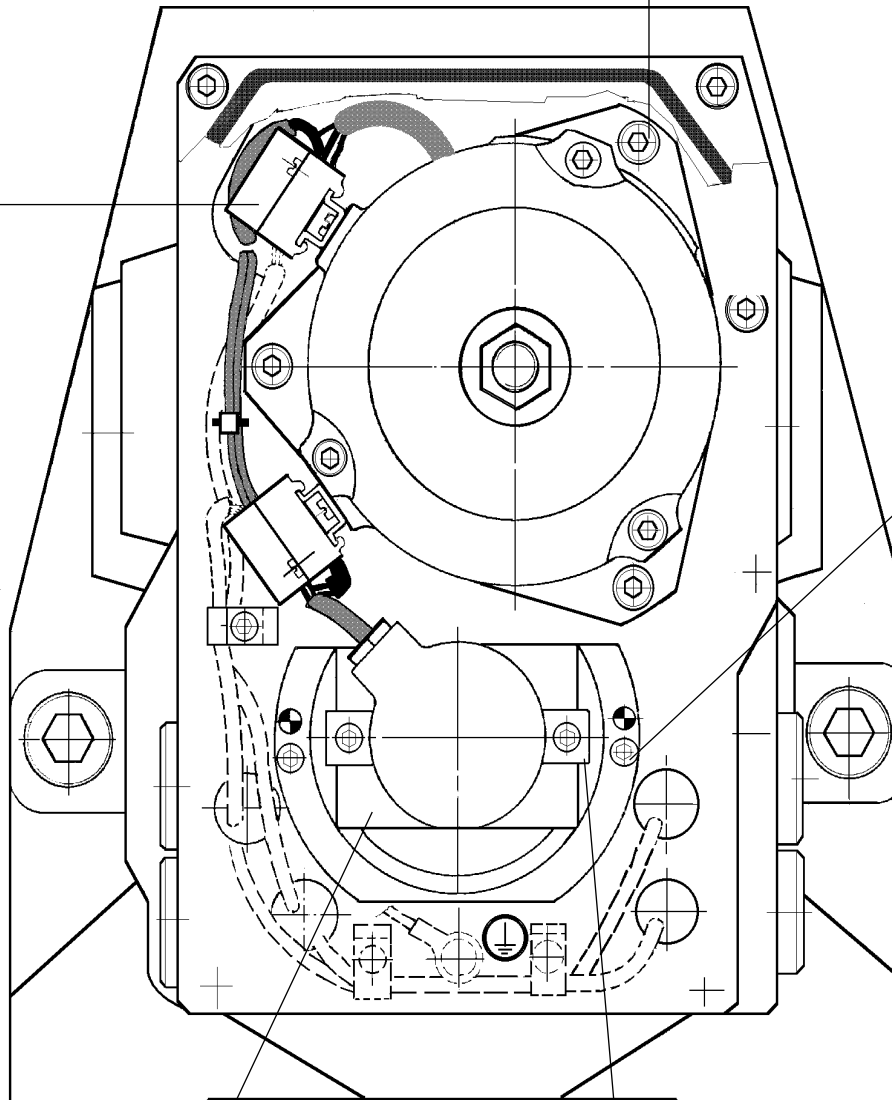

310

311



302

043

067



FROM THE TOP SIDE

Take off the 044 top cover. Remove the screws 300, extract the 042 proximity support with 301 proximity, take off the 049 support with 313 proximity, remove the 046a washers, extract the 200 electromagnet, extract the 017 lock with the related 047 spring. Remove the 019 covers from the two sides, extract the 018 shock absorbing pins complete of 032 pads.

FROM THE REAR SIDE

Take off the 011 cover, untighten the screws 302 and remove the 043 encoder support complete of 160 encoder, take off the 303 seeger, remove the 030 thrust block and the 304 bearing.

FROM THE FRONT SIDE

Take off the toolholder disc, remove the screws 305, take off the dowels 306. Extract the entire central body composed by 003 mobile ring gear, 002 fixed ring gear, 005 indexing head, 006 roller carrier set, 007 spider set, 020 ring nut, 307 belleville washers, 025 - 026 spacers.

If dismantling this set too were necessary, unscrew the ring nut, with a particular tool, and extract all the other components.

Turret size	Diameter R (mm)	Diameter S (mm)
TOE 120	44	8,25
TOE 160	44	8,25
TOE 200	56	8,25
TOE 250	56	8,25
TOE 320	100	10
TOE 400	100	10

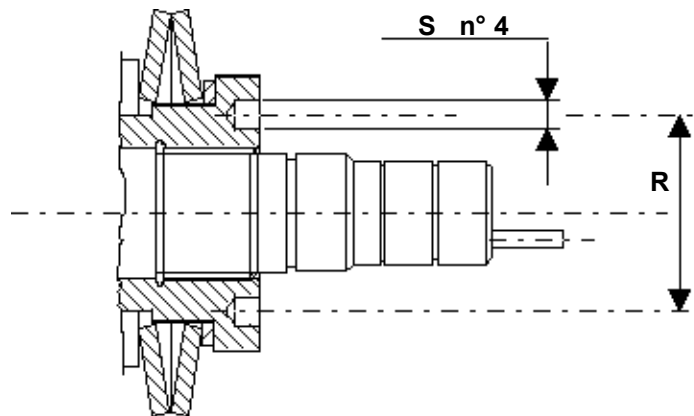

Whenever the turret is disassembled check the state of the following elements which will have to be replaced in case of a negative result:

- principal gasket 308
- all the grommets type (O-ring)
- cushion pads 032

and the following elements (only when the central body has been completely disassembled):

- cam surface
- rollers
- Hirth couplings
- all gears
- supporting palte of the 003 ring gear with the 002 one